

EAZ Series

Close-coupled Centrifugal Pump

User Manual

Content

1. Brief Description
2. Assembly and Disassembly
3. Installation
4. Starting, Checking, Stopping, Running and Maintenance
5. Troubleshooting
6. Installation Dimensions

1. Brief Description

EAZ series are derived from EA series according to the European Standard BS EN733/ DIN24255 of performance.

Pump shaft and motor shaft are close-coupled design. This way of coupling ensures the alignment of pump and motor. Pump impeller runs in good balance both dynamically and statically. Therefore pump would be kept very well in operation. EAZ S, EAZ B, EAZ N are designed to be driven by IEC standard motor, and EAZ S, EAZ B can be assembled separately without motor; EAZ E requires a special motor with extra-long shaft.

Compared by EA pump direct-coupled with motor, EAZ series are much shorter in length thus takes less space to install; and they also can be adjusted into different performance levels through impeller trimming as EA. They are also used for pumping clean water or liquids similar to water, finding great application in industry, city water supply, construction, long-distance transportation, air-conditioning, firefighting and irrigation.

Design	Performance referring to BS EN733/ DIN24255 Standard
Structure	Horizontal, Axially End-Suction, Single-Stage, Single-Suction, Volute Casing, Back pull-out, Close-coupled Centrifugal Pump
Flange	DIN2501 (ISO7005.2 / GB/T17241.6 PN1.6) standard, ANSI B16.5 Class150lb optional
Rotation	Clockwise viewing from the drive side

Material

Casing	Cast iron standard, Ductile Iron, Stainless Steel optional
Impeller	Bronze standard, Ductile Iron, Stainless Steel optional
Shaft	ASTM 420 standard, ASTM 304, ASTM 316, ASTM 1045 optional
Shaft seal	Mechanical seal (Carbon-Sic/Viton)

Operating Data

Flow Rate (Q)	2-555m ³ /h
Head (H)	2-150m
Speed	1450 or 2900 rpm (50Hz) 1750 or 3500 rpm (60Hz)
Temperature	-10°C to 105°C standard
Working Pressure	10 Bar standard, 16Bar on request

Model Form

For example,

EAZ S 65/ 20 - 1850 2 ----- CI - BR - SS - MS - ANSI

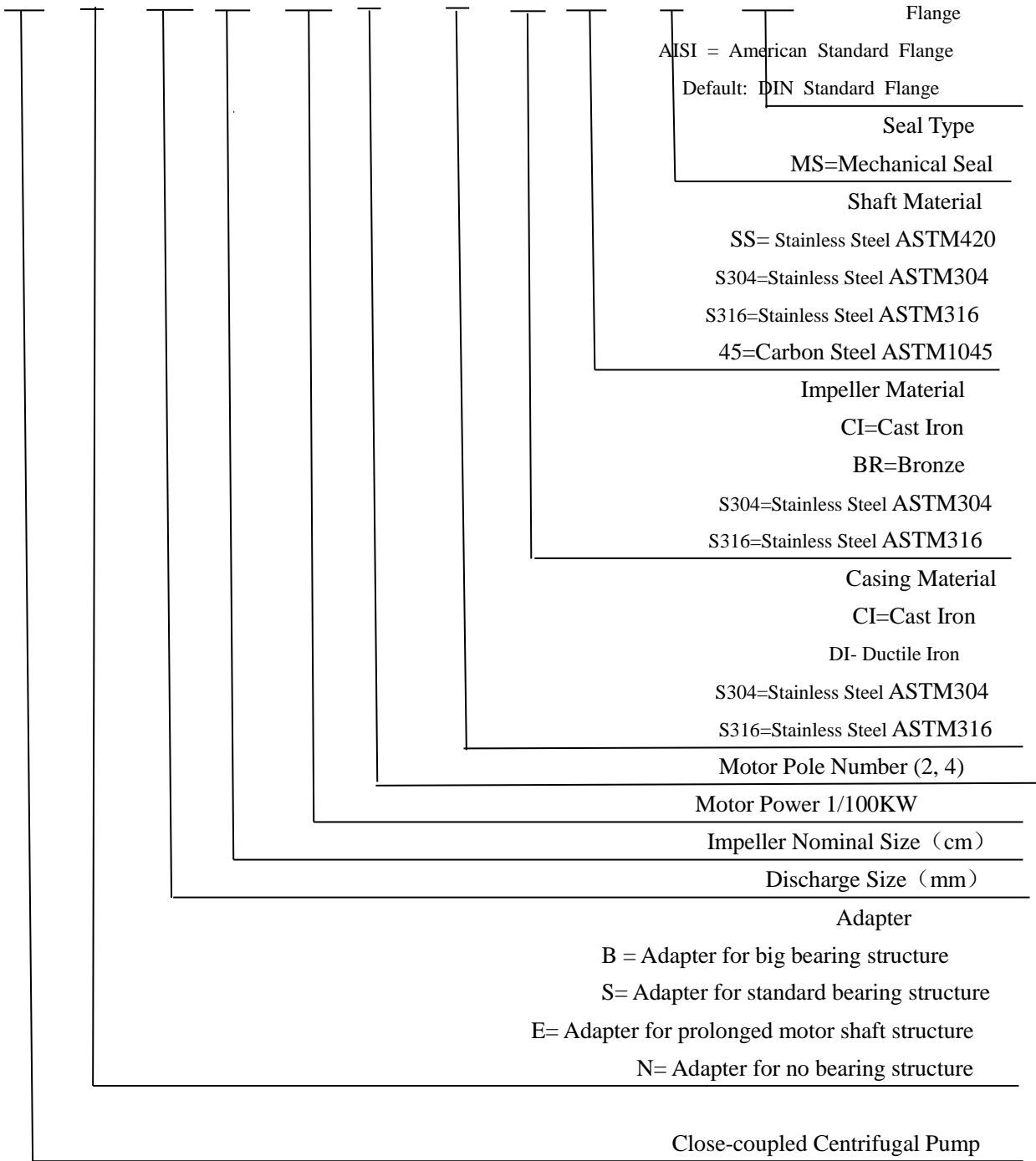

Structure Drawing

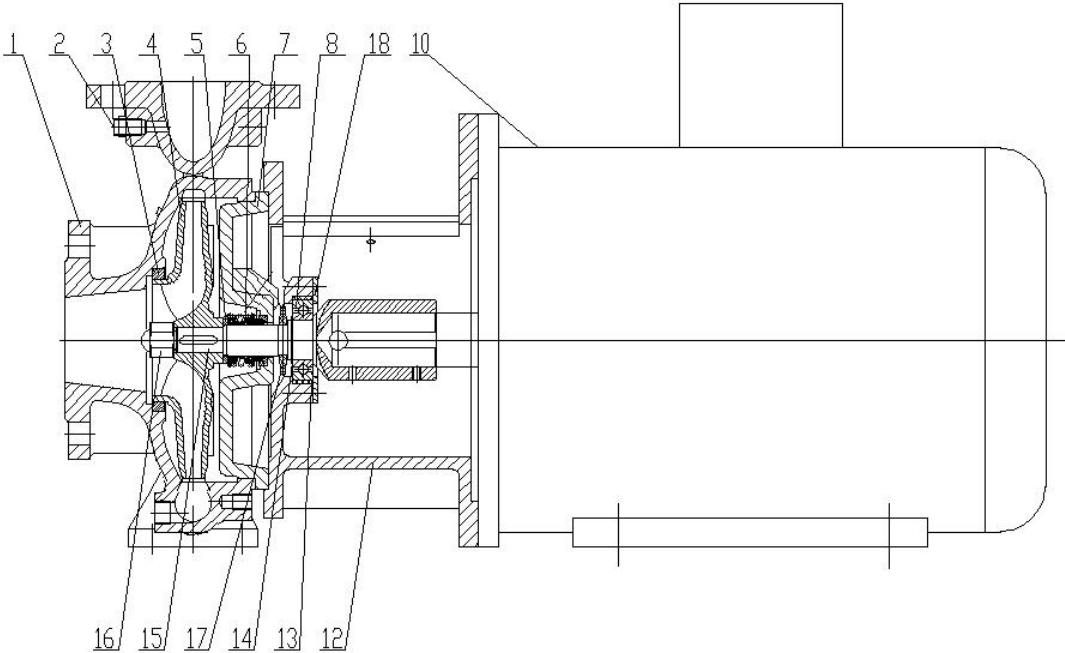

1 EAZ S

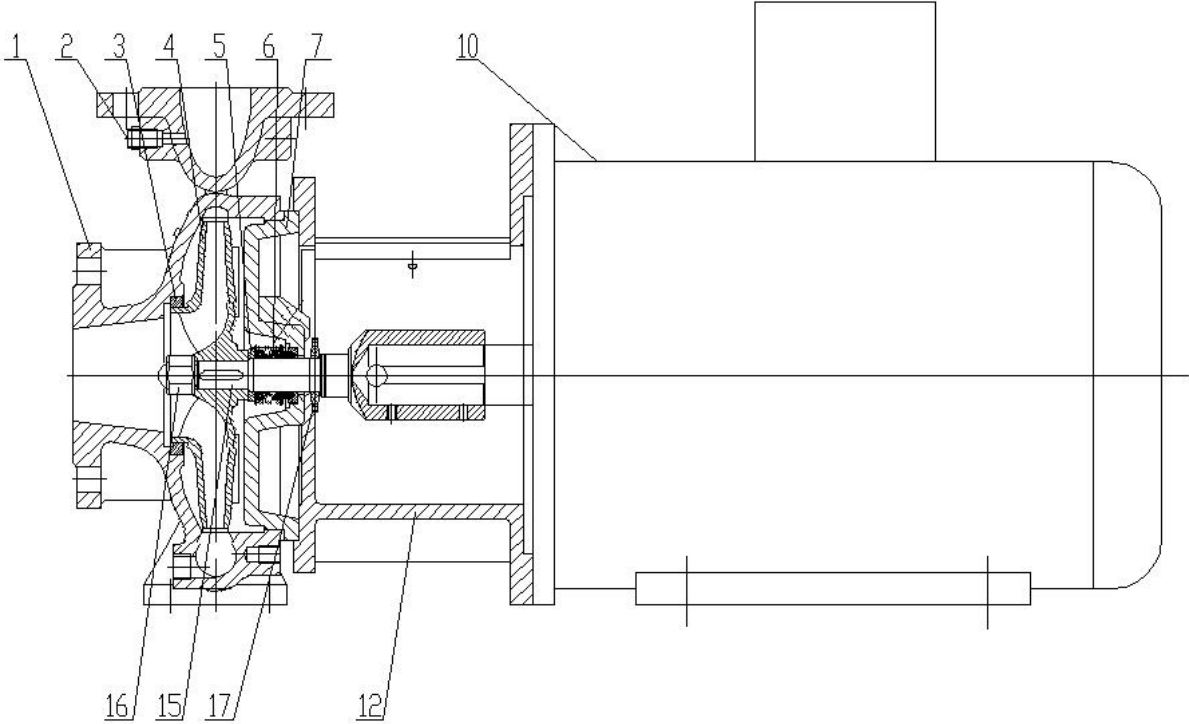

2 EAZ N

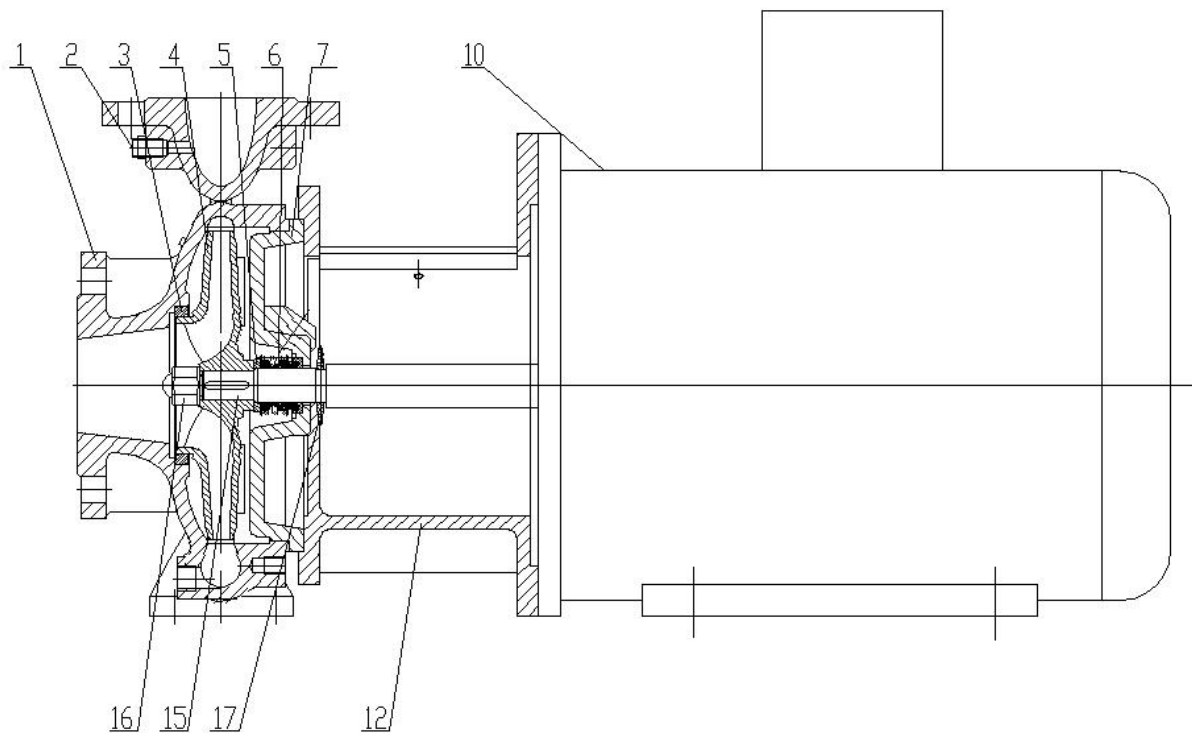

3 EAZ E

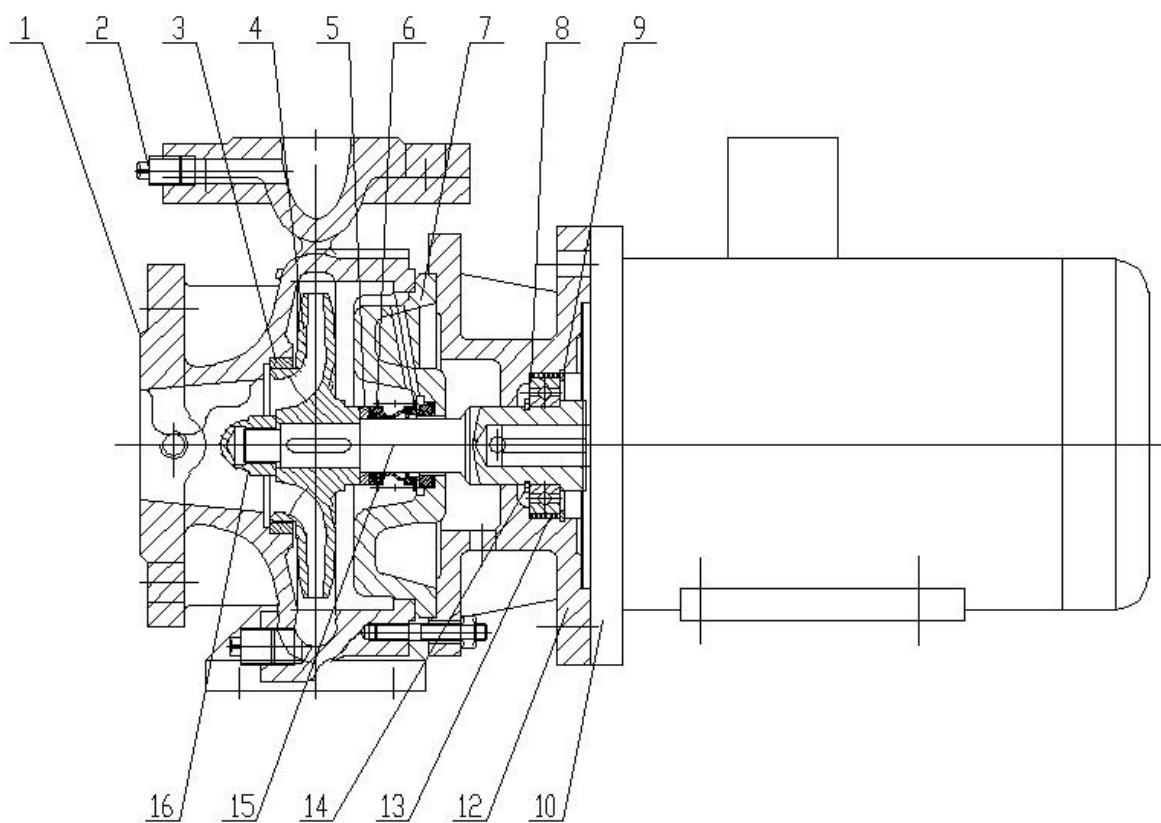

4. (1) EAZ B coupled with motor through adapter only

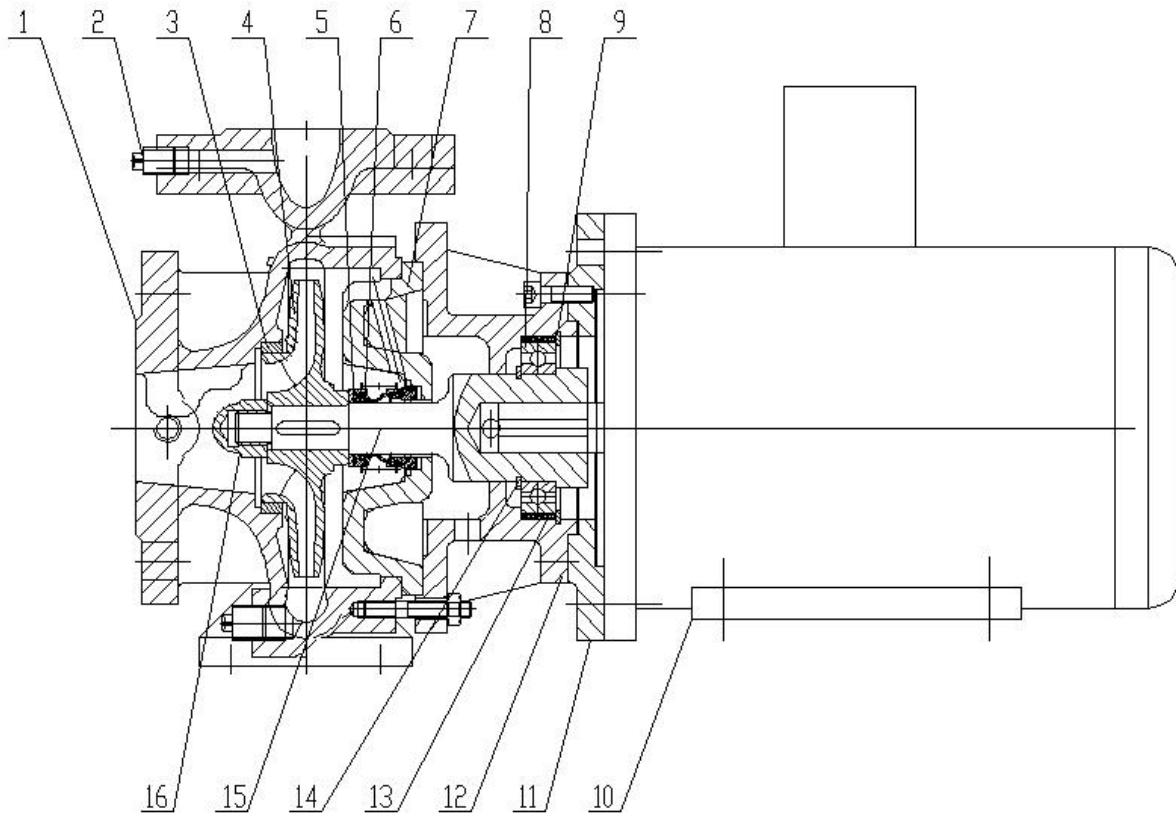

4.(2) EAZ B coupled with motor through adapter and flange

Main Parts

No.	Part Name	No.	Part Name
1	Volute Casing	10	Motor
2	Screw Plug	11	Flange
3	Wear Ring	12	Adapter
4	Impeller	13	Flexible Washer
5	Seal Seat	14	Circlip for shaft
6	Mechanical Seal	15	Shaft
7	Casing Cover	16	Impeller Nut
8	Bearing	17	Slinger
9	Circlip for hole	18	Bearing Cover

Main Parts and Material

Part	Material	China	UK	Japan
		GB	BS	JIS
Casing	Cast Iron	HT200	Gr.180	FC20
	Ductile Iron	QT500-7	Gr.500-7	FCD50
Impeller	Cast Iron	HT200	Gr.180	FC20
	Bronze	ZcuSn5Pb5Zn5	LG2	BC6
	Stainless Steel	2Cr13	420S37	SUS420JI
		0Cr18Ni9	304S15	SUS304
0Cr17Ni12Mo2		316S16	SUS316	
Shaft	Carbon Steel	45	080M46	S45C
	Stainless Steel	2Cr13	420S37	SUS420JI
		0Cr18Ni9	304S15	SUS304
		0Cr17Ni12Mo2	316S16	SUS316
Shaft Sleeve	Stainless Steel	2Cr13	420S37	SUS420JI
Wear Ring	Cast Iron	HT250	Gr.180	FC25
	Bronze	ZcuSn5Pb5Zn5	LG2	BC6

2. Assembly and Disassembly

Ensure no parts are missing or defective before assembly, wipe every part clean then start.

1) Pump body assembly

Screw on plug with PTFE tape for pressure-testing hole and drain hole;

Put paper washer onto casing cover and screw on bolts;

Drive wear ring into pump body;

2) Adapter assembly.

Clean up the shaft, coat grease on bearing position, put on bearing cover(note: no bearing cover in EAZ B pump), push bearing inside by tool up;

Vise the locking ring(circlip for shaft) by caliper, then block it into the shaft ring clasp bed;

Wear flexible gasket on bearing;

Coat grease on adapter's bearing position, then insert shaft components into adapter's bearing position, lock the bearing cover. For EAZ B pump to fixup the bearings is to block the locking ring(circlip for hole) into the clasp bed in adapter;

Mount pump cover properly on adapter (if back wear ring is required, first fit it onto pump cover then mount pump cover onto adapter)

3) General assembly

Coat soapy water or grease on shaft, press in mechanical seal static ring. Pay attention not to scratch static ring surface, pad rubber or plastic plate first before press in the static ring;

Press down seal seat with regular strength, make sure the spring can pop-up;

Put on the key, press impeller, place lock washer, tighten up impeller nut, then bend over lock washer to fixup. And then check the radial runout of impeller and wear ring.

Coat grease on the edge of pump cover, put shaft assembly inside the casing, lock up pump nut tightly.

Motor Mounting (to mount motor or not is subject to customer requirements)

Put the pump horizontally;

Mount on motor key and grease;

Hoist the motor by cranes, put motor shaft into pump shaft slowly, pay attention to the alignment of the two shafts. If it is hard to get coupled, deburr keyway into smooth, note that beating is absolutely prohibited. Fasten the clamping blots in the shaft (EAZ B without any locking blots in the shaft)

Tighten and lock up motor flange bolts to connect motor and adapter.

Disassembly

1) Motor Disassembly: first remove flange bolts and shaft set screws, then remove motor from flange through the screw holes in adapter flange.

2) Pump body Disassembly: remove pump body bolts and studs first, and then use appropriate tools to tear down impeller nut, lock washer, impeller, key, seal seat, mechanical seals, casing cover, bearing cover and other parts one by one.

3. Installation

Correct way of pump installation makes great sense of stable performance and long service life. All the procedure of mounting and adjusting should be carried out carefully. For outline and dimension, see the outline picture and dimension table.

Mounting and adjusting

- 1). Remove all the dust and dirt on base plate then place it onto ground foundation.
- 2). Check foundation level by level meter, iron wedge or steel shims can be used for adjustment.
- 3). Dig foundation bolts holes.
- 4). Check foundation bolts to see if it is loose or not after concretion, and then tighten the bolts, check level again.
- 5). Fix pump and motor onto baseplate, align and level up the support feet of pump and motor with proper pads and then lock them.

4. Starting, Checking, Stopping, Running and Maintenance

4.1. Starting

- 1). Check motor rotation before joint pump and motor together. Ensure that the pump is running freely without friction.
- 2). Turn down discharge valve.
- 3). Fill the pump with liquid or priming with a vacuum pump.
- 4). Switch on power, gradually turn up discharge valve and adjust to the required operating performance..

Caution: The operation time should not be more than 3 minutes while the outlet valve being closed.

4.2 Checking

- 1). Check pump rotation direction: clockwise viewing from the drive side.
- 2). Check alignment between pump and motor. Over-tolerance will cause bad vibration and noise.
- 3). Check mechanical seal, make sure that the pump is operating with water inside, otherwise the dynamic and static rings would be worn out in dry operation.
- 4). Make sure that the bearings are filled with grease or oil.

4.3 Stopping

- 1). Turn down discharge valve gradually, switch off the power.
- 2). Drain away water left inside the pump to avoid frost crack while the temperature is below 0°C.
- 3). To keep a pump out of use for a long time, disassemble and store them in an appropriate place after proper lubrication and packing.

4.4 Running and Maintenance

- 1). Check the readings by the meters in starting and running to make sure that the bearing heating, mechanical seal leakage and heating, pump vibration and noise or other operation issues are under control. Abnormal cases should be handled immediately.
- 2). Bearings are not allowed to work at the temperature 40°C higher than the ambient temperature with the temperature not exceeding 80°C.
- 3). Lubrication should be 4# Calcium Base Grease or SAE20W Oil. Pumps working at 2900 rpm should be replenished with new oil or grease every period of 2500 working hours, 1450 rpm ones should be replenished every 5000 working hours. Ball bearings should be dismantled and replaced by the new ones every 10000 working hours, the chamber should be thoroughly cleaned out and filled with fresh lubrication.

5. Troubleshooting

Defects	Causes	Solutions
Pump not primed, both the hands of vacuum gauge and manometer switches violently	Not enough water filled in the pump Air leakage in the pipe or meters	Filled with water again Fix the leakage
Pump not primed and high degree vacuum indicated on the vacuum gauge	Foot valve not open or clogged Suction resistance too high or suction lift too high	Check or replace the foot valve Clean or replace the inlet pipe Reduce the suction lift
No water discharged while outlet pressure is pointed by the manometer	Wrong direction of rotation Impeller clogged	Check or shorten the pipe Check the motor rotation Remove the pipe joint and clean the impeller
Lower capacity than specified value	Pump clogged Wear ring worn out	Clean pump and pipes Replace the wear ring
Too much power consumed by pump	Packing too tight Stuffing box too hot Impeller worn out Too large flow that the pump is working in.	Loosen gland packing Replace impeller Turn down discharge valve to reduce flow
Abnormal noise inside the pump Pump not primed	Flow too large Resistance too high in the inlet pipe Suction lift too high Air leakage into the inlet pipe Liquid temperature too high	Turn down discharge valve Reduce flow Fix leakage Lower liquid temperature
Bearings over-heart	Short of lubricant or lubricant too dirty Pump shaft not in alignment to that of the motor Bearing worn out	Filled with clean oil or grease Align coupling centerline Replace bearing
Vibration	Pump shaft not in alignment to that of the motor	Align coupling centerline

6. Installation Dimensions