

Product information presented here reflects conditions at time of publication. Consult factory regarding discrepancies or inconsistencies.



TECHNICAL DATA SHEET

Drain Pump Series

Model 105

Remove water from areas where gravity flow is not available.

BASIN FEATURES

- Polypropylene construction
- 2" NPT vent
- 1-1/2" compression slip fit for top and side intake.
- Basin passes the 10' (3 m) stack test (models 104 and 132 will not)
- PVC "Full Flow" check valve with 1-1/2" or 1-1/4" slip X slip union (excludes model 104).
- Threaded connections

MODEL 105

- 1/2" (12 mm) solids-passing capacity
- Temperature rated for 130°F (54°C)
- 1-1/2" NPT discharge
- 1550 RPM on 50 series pumps, 1725 RPM on 90 series
- M53, M55 and M98 with glass-filled polypropylene base
- M59 all bronze construction
- M57 and M63 all cast iron construction
- Includes 1-1/4" or 1-1/2" PVC slip x slip union check valve
- Passes laundry lint
- Automatic, float operated mechanical switch
- 9' (2.7 m), UL Listed, 3-wire cord and plug (15' [5 m] cord standard on model 98)
- Stainless steel screws, guard, handle and switch arm
- Non-clogging vortex impeller

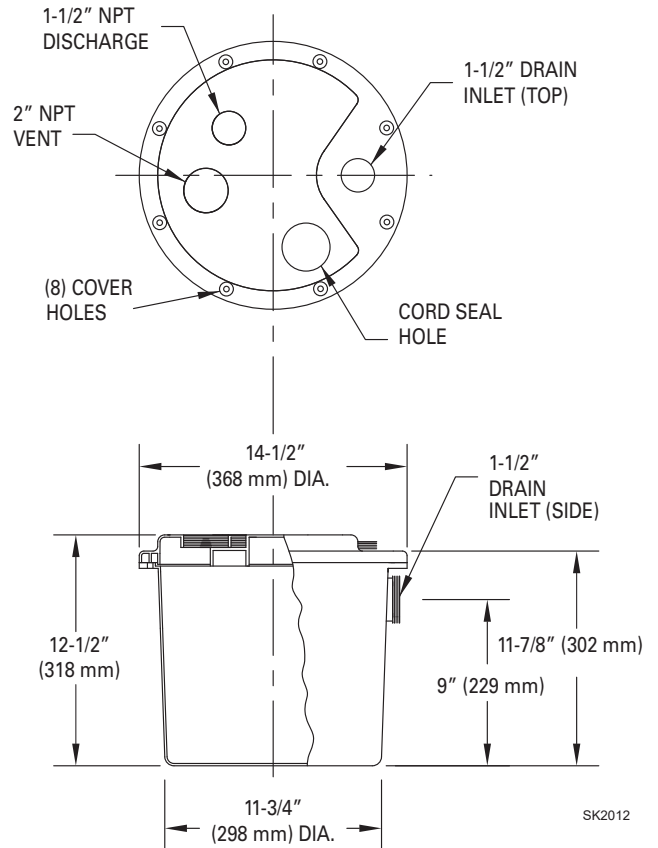

* Models 104 & 132 are not UPC approved.



TOTAL DYNAMIC HEAD FLOW PER MINUTE

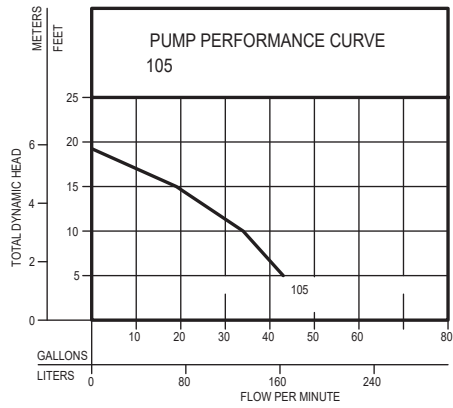

MODELS				105/106 110/115/120			
Feet	Meters	Gal.	Liters	Gal.	Liters	Gal.	Liters
5	1.5			43	163		
10	3.0			34	129		
15	4.6			19	72		
20	6.1	--	--	--	--		
Shut-off Head:				19.25 ft. (5.9m)			

009898

Item No.	Model	MODEL COMPARISON											Limited Warranty
		Seal	Mode	Volts	Discharge	Ph	Amps	HP	Cord (ft)	Hz	Lbs	Kg	
105-0001	105 (M53)	Single	Auto	115	1-1/2"	1	9.7	3/10	9'	60	30	14	36 months

INTERNAL TRAP **
Lavatory Sink

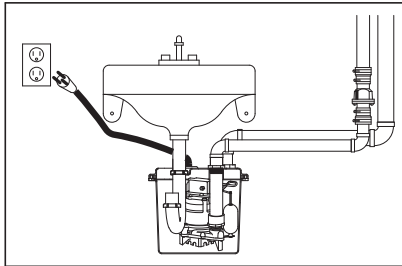

Wet Bar With Sink

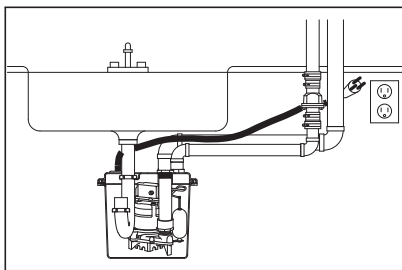

STANDARD INSTALL
Laundry Tray Pump

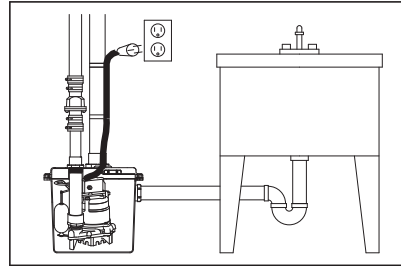

Dehumidifier or Air Conditioner

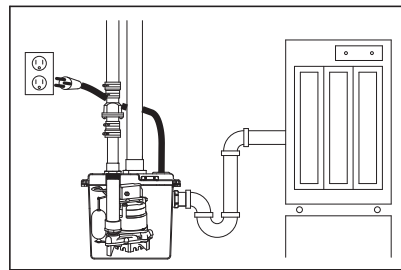

** Trap provided by others

Applications include: laundry tray pump, wet bar sink, lavatory, air conditioning condensate or dehumidifier water removal. It can also be used in conjunction with dishwashers and garbage disposal applications.

SK2011